



LP0313

FITTING INSTRUCTIONS FOR LP0313BK LICENCE PLATE BRACKET
YAMAHA MT-07 '21-



THIS KIT CONTAINS THE ITEMS PICTURED AND LABELLED OVER PAGE.

SOME PARTS MAY BE SHOWN FOR CLARITY OF INSTRUCTIONS ONLY.

DO NOT PROCEED UNTIL YOU ARE SURE ALL PARTS ARE PRESENT.

PLEASE READ ALL INSTRUCTIONS BEFORE PROCEEDING.

**IF IN ANY DOUBT WHEN FITTING OUR PRODUCTS, CONSULT ONE OF OUR DEALERS OR
HAVE FITTED BY A QUALIFIED TECHNICIAN.**

PLEASE NOTE THAT THE WAY THE KIT IS PACKED DOES NOT NECESSARILY REPRESENT THE WAY OF
MOUNTING TO THE BIKE.

IN THE EVENT OF RUBBER WASHERS BEING USED TO HOLD COMPONENTS ONTO BOLTS,
THESE RUBBER WASHERS CAN BE THROWN AWAY.

DIGITAL COPIES OF THESE INSTRUCTIONS ARE AVAILABLE FROM:

WWW.RG-RACING.COM

R&G, Unit 1, Shelley's Lane, East Worldham, Alton, Hampshire, GU34 3AQ
Tel: +44 (0)1420 89007 Fax: +44 (0)1420 87301 www.rg-racing.com Email: info@rg-racing.com



<u>TOOLS REQUIRED</u>	<u>GENERAL TORQUE SETTINGS</u>
<ul style="list-style-type: none"> • HEAT GUN OR LIGHTER • CABLE CUTTERS • ALLEN KEY SET TO INCLUDE 4, 5 & 6MM A/F SIZES. • SMALL FLAT HEAD SCREWDRIVER • SOCKET SET TO INCLUDE 6 & 8MM SOCKETS AND WRENCH. • PHILLIPS SCREWDRIVER. • SMALL AMOUNT OF SUPERGLUE. 	<p>M4 BOLT = 8Nm</p> <p>M5 BOLT = 12Nm</p> <p>M6 BOLT = 15Nm</p> <p>M8 BOLT = 20Nm</p> <p>M10 BOLT = 40Nm</p> <p>M12 BOLT = 40Nm</p>

LEGEND

ITEM NO.	DESCRIPTION	QTY
ITEM 1	TB0313 PART 1 - MAIN BRACKET	1
ITEM 2	TB0313 PART 2 - LICENCE PLATE BRACKET	1
ITEM 3	TB0159 PART 3 - COVER PLATE	1
ITEM 4	LA0002 NUMBER PLATE LIGHT (W/SHROUD)	1
ITEM 5	M6x1.00x16mm BUTTON HEAD BOLTS	4
ITEM 6	M6x1.00x6mm BUTTON HEAD BOLTS	3
ITEM 7	I0037 - OEM INDICATOR ADAPTORS	2
ITEM 8	I0016 - MINI INDICATOR ADAPTORS	4
ITEM 9	RB0002 RUBBER GROMMET	1
ITEM 10	CON0034 MINI INDICATOR CONNECTORS	2
ITEM 11	CON0077 LICENCE PLATE LIGHT CONNECTOR	1
ITEM 12	CT100 - CABLE TIES	3
ITEM 13	230MM LENGTH OF HEAT SHRINK	3
ITEM 14	SELF ADHESIVE CABLE CLIP	2
ITEM 15	IWC0002 INDICATOR WIRING COVERS	2
ITEM 16	REFLECTOR	1
ITEM 17	6.2MM DIAMETER FIR TREE CLIP	1
ITEM 18	7MM DIAMETER QUARTER TURN RIVET	2



LP0313

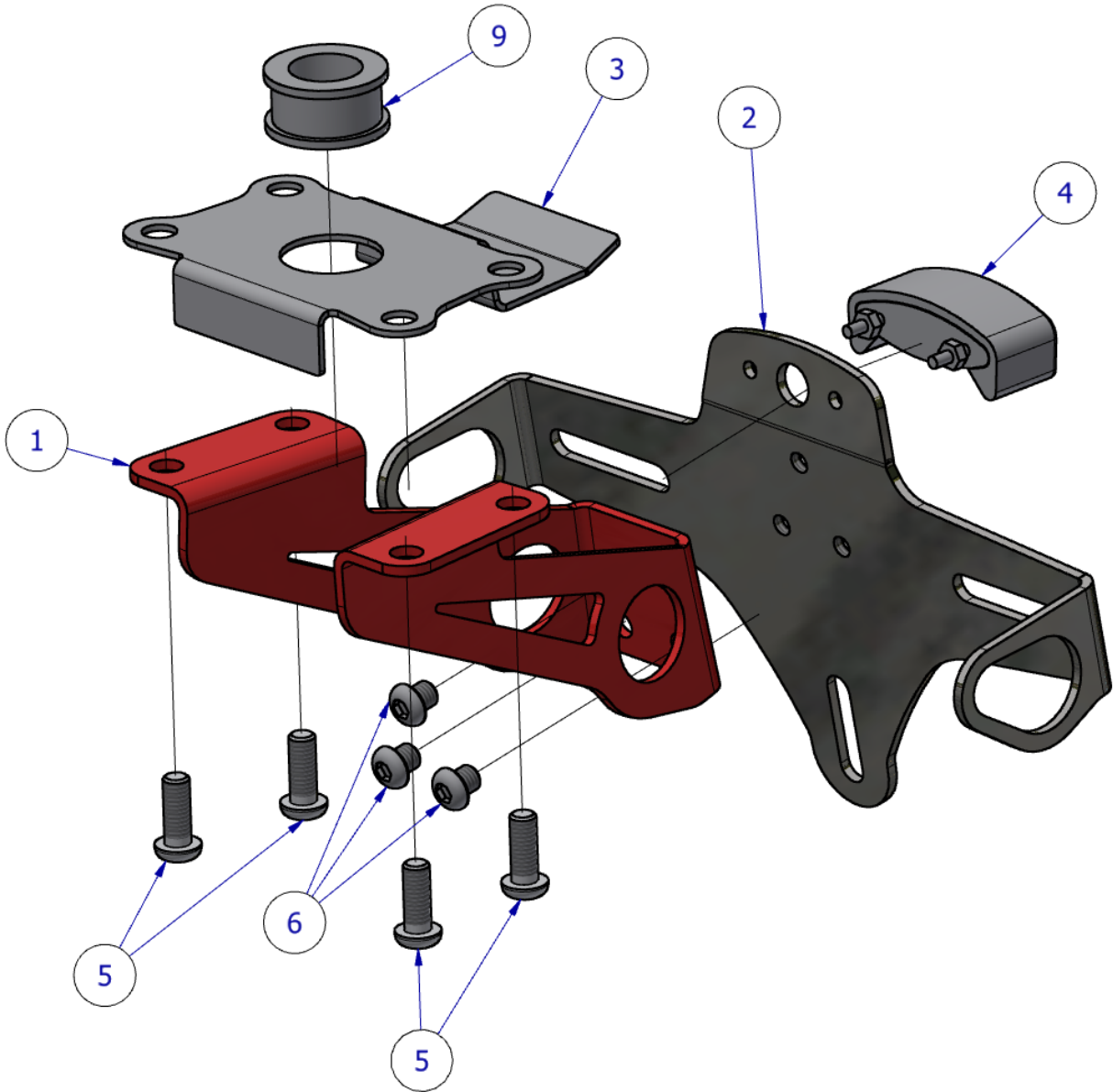

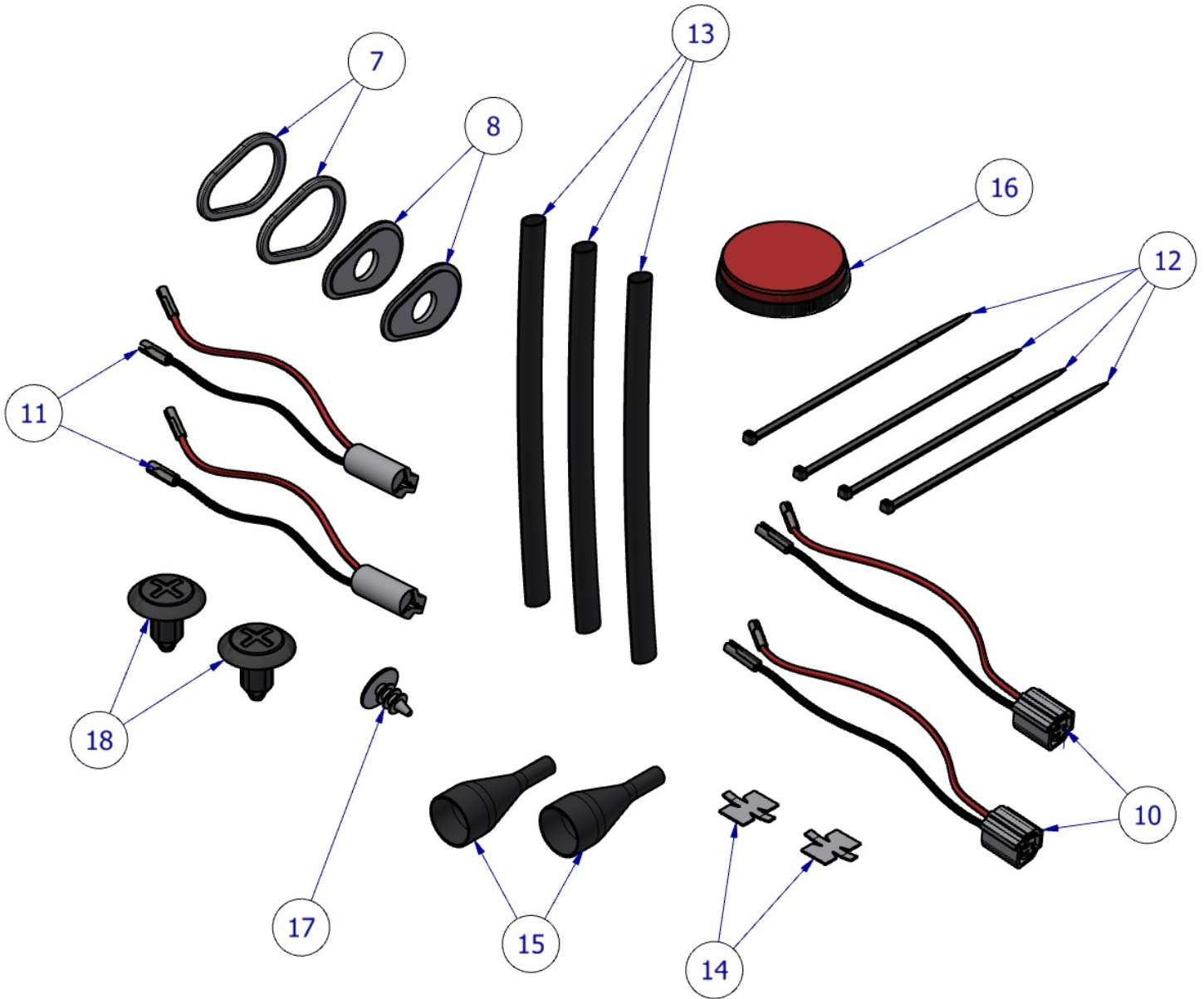



Picture 1

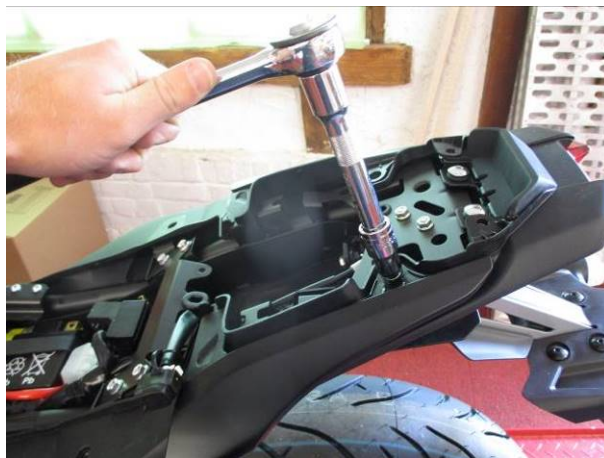

Picture 2



Picture 3



Picture 4



Picture 5



Picture 6



Picture 7



Picture 8



Picture 9



Picture 10

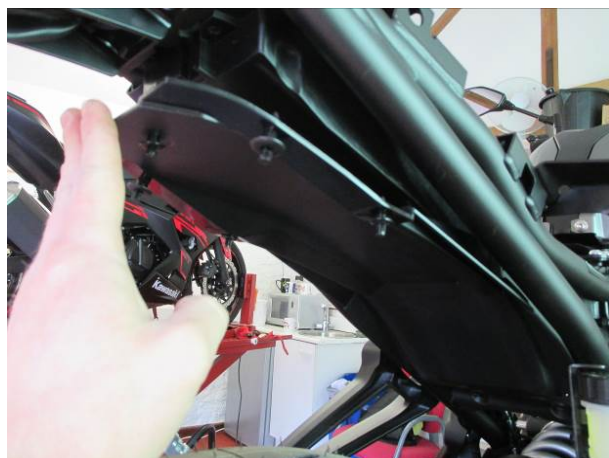

Picture 11



Picture 12



Picture 13



Picture 14



Picture 15



Picture 16



Picture 17



Picture 18



Picture 19



Picture 20

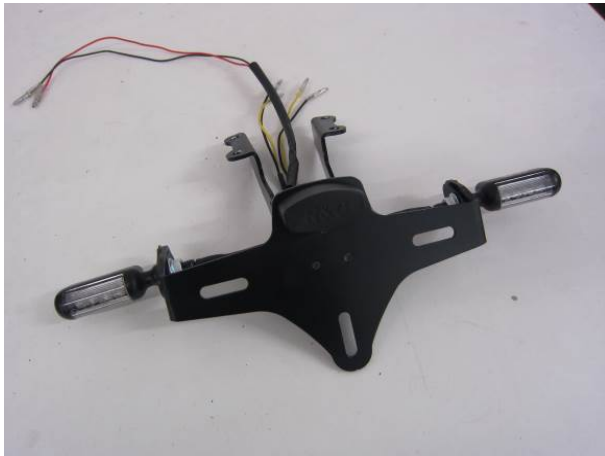

Picture 21



Picture 22



Picture 23



Picture 24

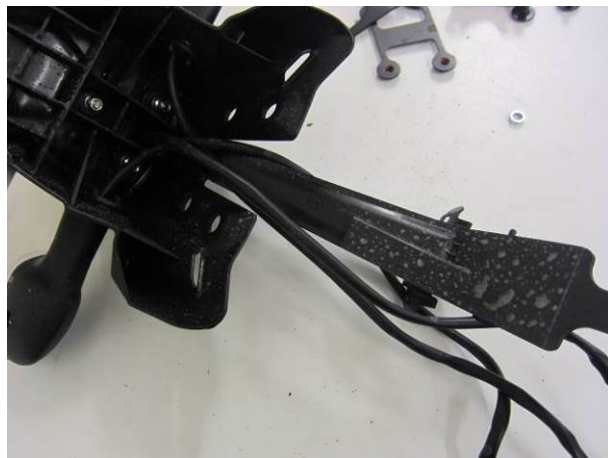

Picture 25



Picture 26



Picture 27



Picture 28



Picture 29



Picture 30



Picture 31



Picture 32

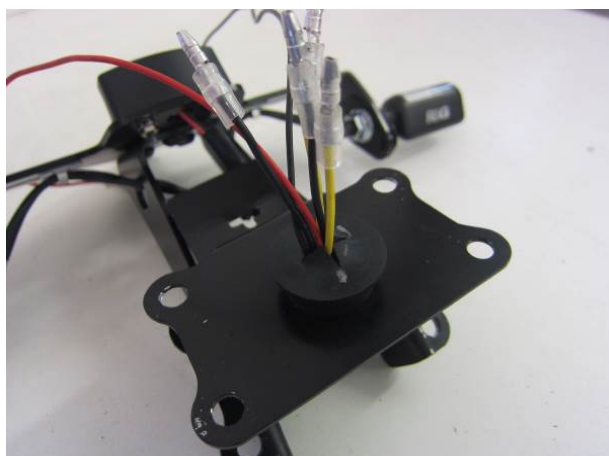

Picture 33



Picture 34



Picture 35



Picture 36



Picture 37



Picture 38



Picture 39



Picture 40





FITTING INSTRUCTIONS

- To fit the R&G tail tidy, remove the pillion seat using the key as shown in picture 1.
- Remove the rider's seat by removing the bolts securing the seat to the frame.
- The rear fairing is made up of two main panels which must be removed. Start by removing the two hex head bolts at the rear of the bike as shown in picture 2.
- Remove the fairing bolt shown in picture 3 from each side of the bike.
- Concealed behind a rubber stop that is held in place you will find two more hex head bolts which must be removed as shown in picture 4 and 5.
- On the underside of the tail unit, remove the five push rivets, as shown in picture 6.
- Next remove the two bolts found on the top at the rear of the motorcycle that hold the rubber joining panel in place, shown in picture 7.
- For each side remove the bolts found at the front of the side panel shown in picture 8.
- You should now be able to gently pull on the rear side panels of the motorcycle and they will release as the locators release from the rubber grommets in the frame as in picture 9 and 10. Pull the whole panel away from the bike evenly to avoid damage to the rear light locators.
- Now the lower splash guard can be removed as in picture 11.
- Inside the tail section, remove the cable tie and disconnect the wiring connectors that relate to the indicators and licence plate illuminator, as shown in picture 12. *It is a good idea to note which connector's match, to make re-fitting easier and mark the indicators left & right. This is particularly important if using R&G Mini Indicators.*
- Remove the four bolts that mount the underside of the OEM licence plate bracket to the bike, and carefully pull away from the bike, as shown in pictures 13 & 14.

To assemble Tail tidy

- Take the R&G licence plate bracket (item 2 – TB0313 Part 2) and fit it to the main bracket (item 1 – TB0313 Part 1) using the three M6 x 6mm long button head bolts (item 6), as shown in pictures 15 & 16.
- Fit the R&G license plate illuminator (item 4) to the assembly, as shown in picture 17. Use a small amount of superglue to stick the light shroud in position. Fit one length of heatshrink to the wires and tighten the nuts on the rear, as shown in picture 18.
- If you intend to re-use the OEM indicators, skip the following stages.

To fit the R&G Mini Indicators

- Take one indicator, remove the nut and fit two of the Mini Indicator Adaptor plates (item 8 – I0016) (stepped faces facing each other) over the wires. (Please use the heat-shrink (item 13) to protect the indicator wires), as shown in picture 19.
- Locate these through either indicator mounting hole, as shown in picture 20.
- Fit the nut to the exposed thread and tighten in place, ensuring the stepped face on the adaptor plates locate correctly on either side of the metal bracket in the hole, as shown in picture 21.
- Place one IWC0002 (item 15) over the wires so that the large end covers the indicator nut.
- Repeat the above four steps for the remaining indicator.
- The wiring can now be fed through the two holes on either side of the main bracket and secured in place using cable ties and the self-adhesive clips, as shown in picture 22 & 31.
- Attach the two CON0034 (item 10) to the indicator wires using the bullet connectors ensuring BLACK to BLACK and YELLOW to BLACK.



To fit the OEM indicators

- The OEM indicators first need to be removed from the OEM licence plate hanger.
- Take the already removed license plate hanger and remove the four bolts, as shown in picture 23.
- With all four bolts removed, the assembly should separate as seen in picture 24.
- Untuck the wiring from the plastic wiring channel, as shown in picture 25.
- On the inside of the indicators, there is a small plastic plate which locates inside the rubber housing of the indicator mount. Remove this plate and gently pull the indicator out of the hole, as shown in pictures 26 & 27.
- Take the OEM Indicator Adaptor plates (item 7 – I0037) and fit one to each indicator rubber, as shown in pictures 28 & 29.
- Locate the indicators through the indicator mounting hole on the tail tidy assembly (placing the correct side indicator on the correct side of the tail tidy, as previously marked on the wiring) and re-fit the small plastic plate inside the rubber to securely mount the indicator, as shown in picture 30.
- For OEM indicators you may need to cut the rubber bung as shown in picture 31 to fit the connector through.

Tail Tidy Fitting

- With indicators now attached CON0077 (item 11) should be attached to the R&G number plate light wires, ensure to match *BLACK to BLACK* and *GREEN to RED*
- The wiring can now be fed through the two holes on either side of the main bracket and secured in place using cable ties and the self-adhesive clips (item 14), as shown in picture 22.
- Take the cover plate (item 3 – TB0159 Part 3) and fit the rubber grommet (item 9) through the central hole, as shown in picture 32.
- Offer up to the tail tidy assembly, ensuring it is orientated the correct way and feed the wiring through the rubber grommet
- Align the four holes and fit the four M6 x 16mm long button head bolts (item 5) through the main bracket and then the cover plate, as shown in picture 33.
- Offer the assembly up to the underside of the bike, feeding the wires through the large hole in the rear subframe, and loosely tighten the four M6 x 16mm long button head bolts (item 5) into the subframe mounts, as shown in pictures 34 & 35. *Whilst tightening, pay attention to the underside of the tail light, as there is a small boss that needs to locate in the "T" shaped cut-out on the metal cover, See picture 36.*
- Now carefully route the wires where they will not obstruct the seat mounting and simply reconnect the indicators and license plate light the correct connector on the main wiring harness, replace the cable clip removed previously as shown in picture 37.
- It is a good idea at this point to turn the ignition on and check for the correct operation of all lights.
- Cable tie the wiring neatly together and re-fit any clips previously removed using the cable ties provided (Item 12).
- Re-fit the plastic undertray, by locating the front tab into its housing, as shown in picture 38.
- Re-fit both side panels to the tail section, ensuring they slot over the undertray correctly, as shown in picture 39.
- Re-fit the bolts and push rivets that secure the side panels in place.
- Re-fit the two OEM push rivets in the front two holes and the two push rivets supplied (item 18) in the rear two holes to secure the side panels to the undertray, as shown in picture 40. In the remaining central hole, fit the pine tree clip (item 17) supplied to blank this hole.
- Re-fit the remaining two bodywork joining panels and Philips screws.
- Ensure all bolts are tightened evenly.
- Re-fit the seat, securely mount the two bolts and re-fit the pillion seat.

R&G, Unit 1, Shelley's Lane, East Worldham, Alton, Hampshire, GU34 3AQ

Tel: +44 (0)1420 89007 Fax: +44 (0)1420 87301 www.rg-racing.com Email: info@rg-racing.com



- Re-fit the licence plate (it may require drilling).
- **IMPORTANT: IF FITTING A FULL-SIZE LICENCE PLATE AND PLACING IT FAR DOWN ON THE LICENCE PLATE HANGER, THERE IS A SMALL CHANCE OF THE LICENCE PLATE HITTING THE BACK WHEEL UNDER HEAVY LOAD AND OVER LARGE BUMPS IN THE ROAD. IT IS YOUR RESPONSIBILITY TO CHECK FOR THIS POSSIBILITY AND TAKE AVOIDING ACTION. FAILURE TO CHECK THIS COULD RESULT IN SERIOUS INJURY.**
- Depending on local laws, attach enclosed reflector (item 17) in an appropriate location.
- Test the license plate illuminator and all lights before riding.

ISSUE 1 28/07/21 (DM)

CONSUMER NOTICE

The catalogue description and any exhibition of samples are only broad indications of the Products and R&G may make design changes which do not diminish their performance or visual appeal and supplying them in such state shall conform to the order. The Buyer acknowledges no representation or warranty (other than as to title) has been given or will apply to the Products other than those in R&G's order or confirmation and the Buyer confirms it has chosen the Products as being of merchantable quality and suitable for its particular purposes. Where R&G fits the Products or undertakes other services it shall exercise reasonable skill and care and rectify any fault free of charge unless the workmanship has been disturbed. The Buyer is responsible for ensuring that the warranty on the motorcycle is not affected by the fitting of the Products. On return of any defective Products R&G shall at its option either supply a replacement or refund the purchase money but shall not be liable if the Products have been modified or used or maintained otherwise than in accordance with R&G's or manufacturer's instructions and good engineering practice or if the defect arises from accident or neglect. Other than identified above and subject to R&G not limiting its liability for causing death and personal injury, it shall not be liable for indirect or consequential loss and otherwise its liability shall be limited to the amounts paid by the Buyer for the Products or the fitting or service concerned. These terms do not affect the Buyer's statutory rights.

R&G RETURNS POLICY (NON-FAULTY GOODS)

Returns must be pre-authorized (if not pre-authorized the return will be rejected). Goods may only be returned direct to us if they were purchased direct from us (customer must prove if necessary). Otherwise to be returned to original vendor. Goods must be in re-sellable condition, in the opinion of R&G. All returns are subject to a 25% restocking and handling fee (25% of the gross value exc. P&P – at the prevailing price at time of purchase). The customer must pay any and all carriage charges. No returns of discontinued products, unless within 14 days of purchase. This policy does not affect your statutory rights and does not refer to faulty goods.



LP0313

NOTICE DE MONTAGE POUR LP0313BK SUPPORT DE PLAQUE
YAMAHA MT-07 '21-



CE KIT CONTIENT LES ARTICLES ILLUSTRÉS ET ÉTIQUETES SUR LA PAGE.

CERTAINES PARTIES PEUVENT ÊTRE PRÉSENTES UNIQUEMENT POUR LA CLARTÉ DES INSTRUCTIONS.

NE PAS PROCÉDER AU MONTAGE TANT QUE VOUS N'ÊTES PAS SÛR QUE TOUTES LES PIÈCES SOIENT PRÉSENTES.

VEUILLEZ LIRE TOUTES LES INSTRUCTIONS AVANT DE CONTINUER.

**EN CAS DE DOUTE LORS DU MONTAGE DE NOS PRODUITS, CONSULTEZ UN DE NOS
REVENDEURS OU FAITES APPEL À UN TECHNICIEN QUALIFIÉ.**

VEUILLEZ NOTER QUE LA FAÇON DONT LE KIT EST EMBALLÉ NE REPRÉSENTE PAS NECESSAIREMENT LA
MANIÈRE DE LE MONTER SUR LA MOTO.

SI DES RONDELLES EN CAOUTCHOUC SONT UTILISÉES POUR MAINTENIR LES COMPOSANTS SUR LES
BOULONS, ELLES PEUVENT ÊTRE JETÉES.

NOTICE DISPONIBLE AU TÉLÉCHARGEMENT SUR :
WWW.RG-RACING.COM



<u>OUTILS REQUIS</u>	<u>VALEURS DE SERRAGE</u>
<ul style="list-style-type: none"> • PISTOLET À CHALEUR • PINCE COUPANTE • CLÉS ALLEN 4, 5 & 6MM. • TOURNEVIS PLAT • CLÉ À CLIQUET + DOUILLES 6 & 8MM • TOURNEVIS CRUCIFORME. • UN PEU DE SUPERGLUE. 	<p>M4 BOULON = 8Nm</p> <p>M5 BOULON = 12Nm</p> <p>M6 BOULON = 15Nm</p> <p>M8 BOULON = 20Nm</p> <p>M10 BOULON = 40Nm</p> <p>M12 BOULON = 40Nm</p>

LÉGENDE

ARTICLE NO.	DESCRIPTION	QTÉ
ARTICLE 1	TB0313 PART 1 - SUPPORT PRINCIPAL	1
ARTICLE 2	TB0313 PART 2 - SUPPORT DE PLAQUE	1
ARTICLE 3	TB0159 PART 3 - COUVERCLE	1
ARTICLE 4	LA0002 FEU DE PLAQUE (W/LINCEUL)	1
ARTICLE 5	M6x1.00x16mm BOULONS	4
ARTICLE 6	M6x1.00x6mm BOULONS	3
ARTICLE 7	I0037 - ADAPTATEURS DE CLIGNOTANT D'ORIGINE	2
ARTICLE 8	I0016 - ADAPTATEURS DE MINI CLIGNOTANT	4
ARTICLE 9	RB0002 OEILLET EN CAOUTCHOUC	1
ARTICLE 10	CON0034 CONNECTEURS DE MINI CLIGNOTANTS	2
ARTICLE 11	CON0077 CONNECTEUR DE FEU DE PLAQUE	1
ARTICLE 12	CT100 - COLLIERS DE SERRAGE	3
ARTICLE 13	230MM MANCHON THERMO RÉTRACTABLE	3
ARTICLE 14	CLIP CÂBLE AUTOCOLLANT	2
ARTICLE 15	IWC0002 CACHES FILS DE CLIGNOTANT	2
ARTICLE 16	RÉFLECTEUR	1
ARTICLE 17	6.2MM DIAMÈTRE PINCE SAPIN	1
ARTICLE 18	7MM RIVET QUART DE TOUR DIAMÈTRE	2



LP0313

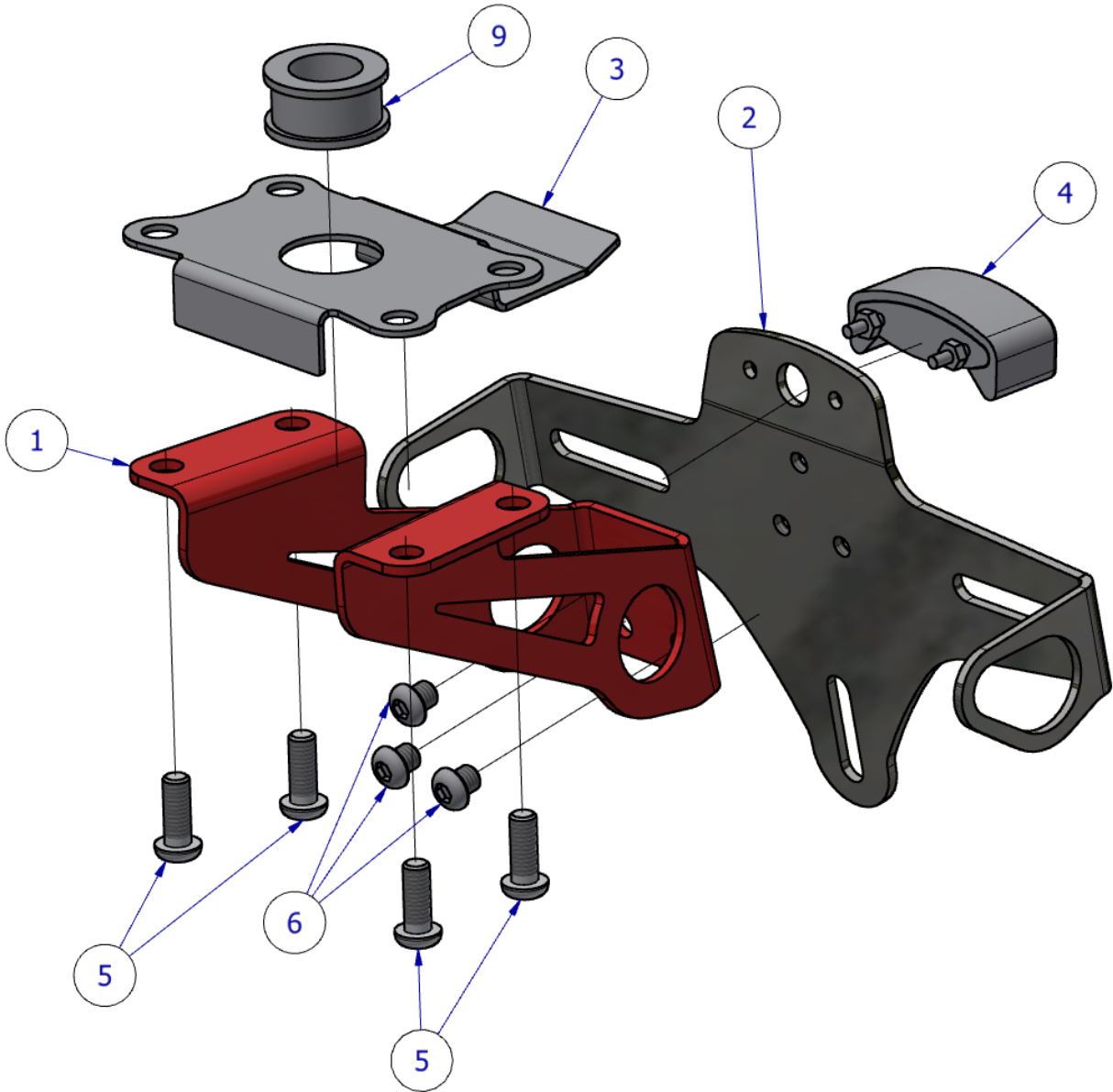

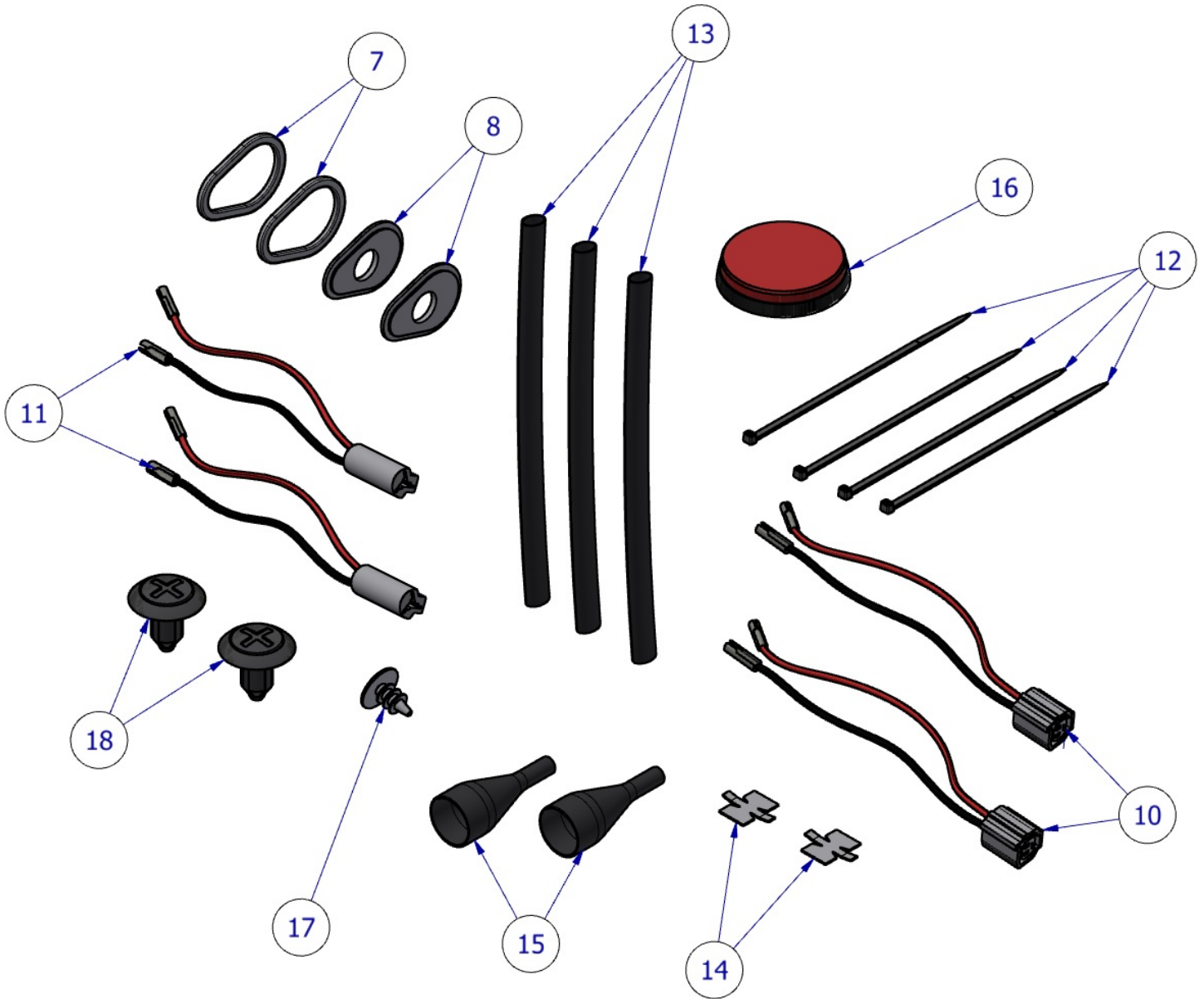



Photo 1

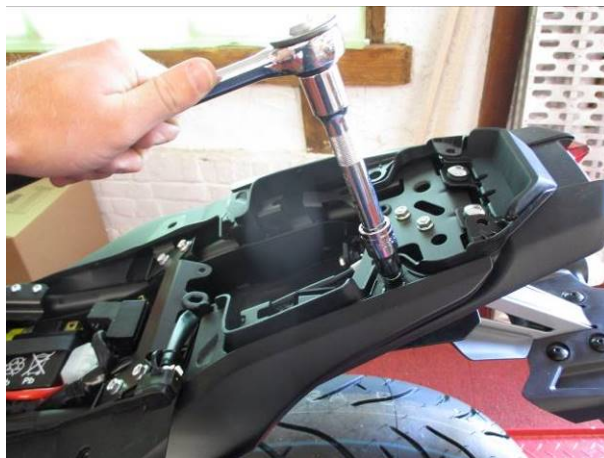

Photo 2



Photo 3



Photo 4



Photo 5



Photo 6



Photo 7



Photo 8



Photo 9



Photo 10



Photo 11



Photo 12



Photo 13



Photo 14



Photo 15



Photo 16



Photo 17



Photo 18



Photo 19



Photo 20

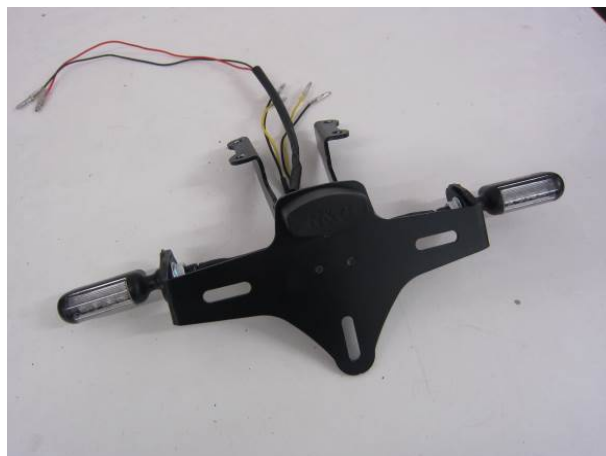

Photo 21

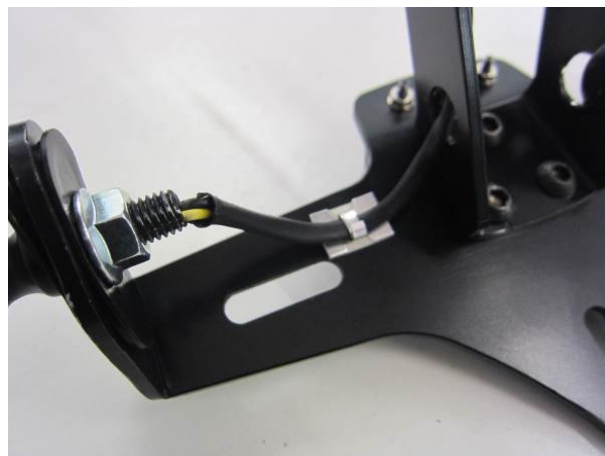

Photo 22



Photo 23



Photo 24

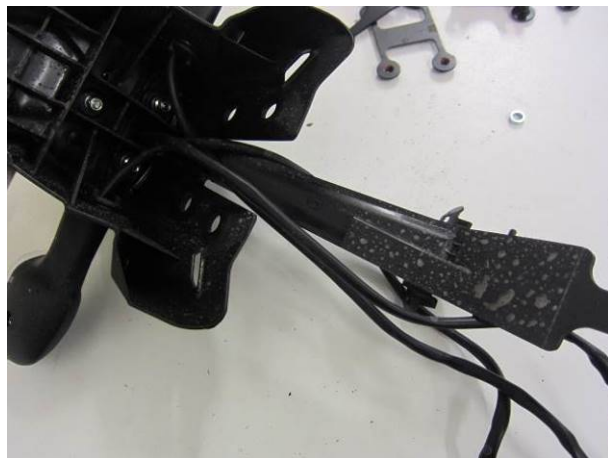

Photo 25



Photo 26



Photo 27



Photo 28



Photo 29



Photo 30



Photo 31



Photo 32

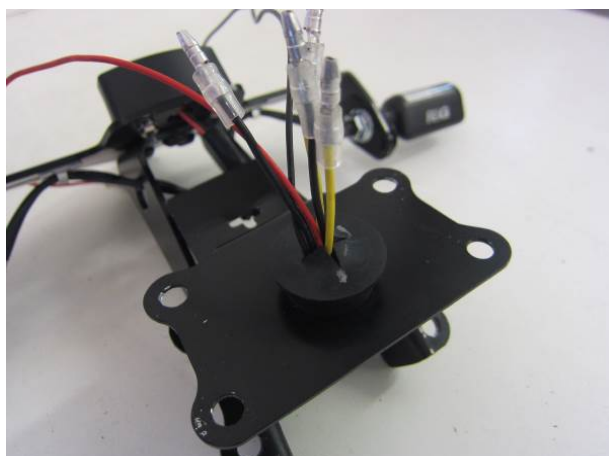

Photo 33

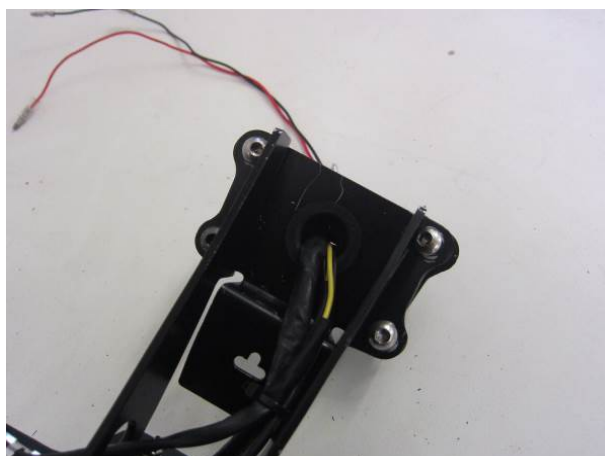

Photo 34



Photo 35



Photo 36



Photo 37



Photo 38



Photo 39



Photo 40





NOTICE DE MONTAGE

- Pour monter le support arrière R&G, retirez la selle passager à l'aide de la clé comme indiqué sur la photo 1.
- Retirez la selle du pilote en enlevant les boulons fixant la selle au cadre.
- Le carénage arrière est composé de deux panneaux principaux qui doivent être retirés. Commencez par retirer les deux boulons à tête hexagonale à l'arrière de la moto comme indiqué sur la photo 2.
- Retirez le boulon de carénage illustré sur la photo 3 de chaque côté de la moto.
- Caché derrière une butée en caoutchouc qui est maintenue en place, vous trouverez deux autres boulons à tête hexagonale qui doivent être retirés comme indiqué sur les photos 4 et 5.
- Sur la face inférieure de l'empennage, retirez les cinq rivets poussoirs, comme indiqué sur la photo 6.
- Retirez ensuite les deux boulons situés sur le dessus à l'arrière de la moto qui maintiennent le panneau de jonction en caoutchouc en place, illustré sur la photo 7.
- Pour chaque côté, retirez les boulons situés à l'avant du panneau latéral illustré à la photo 8.
- Vous devriez maintenant être en mesure de tirer doucement sur les panneaux latéraux arrière de la moto et ils se relâcheront lorsque les onglets se dégageront des œillets en caoutchouc du cadre, comme sur les photos 9 et 10. Éloignez uniformément le panneau de la moto pour éviter de faire des dommages sur les onglets de feu arrière.
- Maintenant, le garde-boue inférieur peut être retiré comme sur la photo 11.
- À l'intérieur de la section arrière, retirez le serre-câbles et débranchez les connecteurs de câblage qui se rapportent aux clignotants et à l'éclairage de plaque d'immatriculation, comme indiqué sur la photo 12. Il est judicieux de noter quel connecteur correspond, pour faciliter le remontage et marquer les clignotants gauche et droit. Ceci est particulièrement important si vous utilisez les mini-clignotants R&G.
- Retirez les quatre boulons qui fixent le dessous du support de plaque d'immatriculation d'origine sur la moto et retirez-le soigneusement de la moto, comme indiqué sur les photos 13 et 14.

Assemblage du support de plaque

- Prenez le support de plaque d'immatriculation R&G (article 2 – TB0313 Partie 2) et fixez-le au support principal (article 1 – TB0313 Partie 1) à l'aide des trois boulons à tête ronde M6 x 6 mm (article 6), comme indiqué sur les photos 15 & 16.
- Monter le feu de plaque d'immatriculation R&G (article 4) sur l'ensemble, comme indiqué sur la photo 17. Utiliser une petite quantité de superglue pour coller le linceul de feu en place. Installez une longueur de gaine thermorétractable sur les fils et serrez les écrous à l'arrière, comme indiqué sur la photo 18.
- Si vous avez l'intention de réutiliser les clignotants d'origine, ignorez les étapes suivantes.

Pour monter les mini clignotants R&G

- Prenez un clignotant, retirez l'écrou et placez deux des plaques d'adaptation de mini clignotant (article 8 – I0016) (faces étagées se faisant face) sur les fils. (Veuillez utiliser le thermorétractable (article 13) pour protéger les fils de clignotants), comme indiqué sur la photo 19.
- Placez-les dans l'un des trous de montage de clignotant, comme illustré sur la photo 20.
- Montez l'écrou sur le filetage exposé et serrez en place, en vous assurant que la face étagée des plaques d'adaptation se place correctement de chaque côté du support métallique dans le trou, comme illustré sur la photo 21.
- Placer un IWC0002 (article 15) sur les fils de sorte que la grande extrémité recouvre l'écrou de clignotant.
- Répétez les quatre étapes ci-dessus pour le clignotant restant.

R&G, Unit 1, Shelley's Lane, East Worldham, Alton, Hampshire, GU34 3AQ

Tel: +44 (0)1420 89007 Fax: +44 (0)1420 87301 www.rg-racing.com Email: info@rg-racing.com



- Le câblage peut maintenant être passé à travers les deux trous de chaque côté du support principal et fixé en place à l'aide des attaches de câble et des clips autocollants, comme indiqué sur les photos 22 et 31.
- Attachez les deux CON0034 (article 10) aux fils de clignotant à l'aide des connecteurs en veillant à respecter cette combinaison NOIR à NOIR et JAUNE à NOIR.

Pour installer les clignotants d'origine

- Les clignotants d'origine doivent d'abord être retirés du support de plaque d'immatriculation d'origine.
- Prenez le support de plaque d'immatriculation déjà retiré et retirez les quatre boulons, comme indiqué sur la photo 23.
- Une fois les quatre boulons retirés, l'assemblage devrait se séparer comme le montre la photo 24.
- Détachez le câblage du canal de câblage en plastique, comme indiqué sur la photo 25.
- À l'intérieur des clignotants, il y a une petite plaque en plastique qui se situe à l'intérieur du boîtier en caoutchouc du support de clignotant. Retirez cette plaque et tirez doucement le clignotant hors du trou, comme indiqué sur les photos 26 et 27.
- Prenez les plaques d'adaptation de clignotant d'origine (article 7 - I0037) et installez-en une sur chaque caoutchouc de clignotant, comme indiqué sur les photos 28 et 29.
- Localisez les clignotants à travers le trou de montage de clignotant sur l'ensemble du support arrière (en plaçant le clignotant latéral correct sur le bon côté du support arrière, comme indiqué précédemment sur le câblage) et réinstallez la petite plaque en plastique à l'intérieur du caoutchouc pour un montage sûr le clignotant, comme le montre la photo 30.
- Pour les clignotants d'origine, vous devrez peut-être couper le bouchon en caoutchouc comme indiqué sur la photo 31 pour faire passer le connecteur à travers.

Montage du support de plaque

- Une fois les clignotants attachés, le CON0077 (article 11) aux fils de feu de plaque d'immatriculation R&G, assurez-vous de faire correspondre le NOIR au NOIR et le VERT au ROUGE.
- Le câblage peut maintenant être passé à travers les deux trous de chaque côté du support principal et fixé en place à l'aide de serre-câbles et de clips autocollants (article 14), comme indiqué sur la photo 22.
- Prendre le couvercle (article 3 – TB0159 Partie 3) et insérer le passe-fil en caoutchouc (article 9) à travers le trou central, comme indiqué sur la photo 32.
- Présentez le sur l'ensemble du support, en vous assurant qu'il soit orienté dans le bon sens et faites passer le câblage à travers le passe-fil en caoutchouc.
- Alignez les quatre trous et placez les quatre boulons à tête ronde M6 x 16 mm de long (article 5) à travers le support principal puis la plaque de recouvrement, comme indiqué sur la photo 33.
- Présentez l'assemblage au dessous de la moto, en passant les fils à travers le grand trou dans le sous-châssis arrière, et serrez sans serrer les quatre boulons à tête ronde M6 x 16 mm de long (article 5) dans les supports du sous-châssis, comme indiqué sur les photos 34 & 35. Lors du serrage, faites attention au dessous du feu arrière, car il y a un petit bossage qui doit se localiser dans la découpe en forme de "T" sur le couvercle métallique, Voir photo 36.
- Acheminez maintenant soigneusement les fils là où ils n'obstrueront pas le montage du siège reconnectez simplement les clignotants et la plaque d'immatriculation au bon connecteur sur le harnais principal, remplacez le serre-câble retiré précédemment comme indiqué sur la photo 37.
- C'est une bonne idée à ce stade de mettre le contact et de vérifier le bon fonctionnement de tous les feux.
- Attachez soigneusement les câbles entre eux et remontez les clips éventuellement retirés à l'aide des serre-câbles fournis (Article 12).

R&G, Unit 1, Shelley's Lane, East Worldham, Alton, Hampshire, GU34 3AQ

Tel: +44 (0)1420 89007 Fax: +44 (0)1420 87301 www.rg-racing.com Email: info@rg-racing.com



- Remonter le passage de roue en plastique, en logeant la languette avant dans son logement, comme indiqué sur la photo 38.
- Remontez les deux panneaux latéraux sur la section arrière en vous assurant qu'ils s'emboîtent correctement sur le passage de roue, comme indiqué sur la photo 39.
- Remontez les boulons et les rivets poussoirs qui maintiennent les panneaux latéraux en place.
- Remonter les deux rivets poussoirs d'origine dans les deux trous avant et les deux rivets poussoirs fournis (article 18) dans les deux trous arrière pour fixer les panneaux latéraux au passage de roue, comme indiqué sur la photo 40. Dans le trou central restant, monter le clip sapin (article 17) fourni pour obturer ce trou.
- Remonter les deux panneaux de jonction de carénage restants et les vis cruciformes.
- Assurez-vous que tous les boulons soient serrés uniformément.
- Remonter la selle, fixer solidement les deux vis et remonter la selle passage.
- Remontez la plaque d'immatriculation (elle peut nécessiter un perçage).
- **IMPORTANT: SI VOUS INSTALLEZ UNE PLAQUE D'IMMATRICULATION DE GRANDE TAILLE ET LA PLACEZ LOIN VERS LE BAS SUR LE SUPPORT DE PLAQUE D'IMMATRICULATION, IL Y A UNE FAIBLE CHANCE QUE LA PLAQUE D'IMMATRICULATION FRAPPE LA ROUE ARRIÈRE SOUS L'EFFET D'UNE CHARGE LOURDE ET SUR DE GRANDES BOSSES SUR LA ROUTE. IL EST DE VOTRE RESPONSABILITÉ DE VÉRIFIER CETTE POSSIBILITÉ ET DE PRENDRE DES MESURES POUR L'ÉVITER. NE PAS VÉRIFIER CECI POURRAIT ENTRAÎNER DES BLESSURES GRAVES.**
- Selon les lois locales, fixez le réflecteur inclus (article 17) à un endroit approprié.
- Testez l'éclairage de plaque d'immatriculation et tous les feux avant de rouler.

ISSUE 1 28/07/21 (DM)

CONSUMER NOTICE

The catalogue description and any exhibition of samples are only broad indications of the Products and R&G may make design changes which do not diminish their performance or visual appeal and supplying them in such state shall conform to the order. The Buyer acknowledges no representation or warranty (other than as to title) has been given or will apply to the Products other than those in R&G's order or confirmation and the Buyer confirms it has chosen the Products as being of merchantable quality and suitable for its particular purposes. Where R&G fits the Products or undertakes other services it shall exercise reasonable skill and care and rectify any fault free of charge unless the workmanship has been disturbed. The Buyer is responsible for ensuring that the warranty on the motorcycle is not affected by the fitting of the Products. On return of any defective Products R&G shall at its option either supply a replacement or refund the purchase money but shall not be liable if the Products have been modified or used or maintained otherwise than in accordance with R&G's or manufacturer's instructions and good engineering practice or if the defect arises from accident or neglect. Other than identified above and subject to R&G not limiting its liability for causing death and personal injury, it shall not be liable for indirect or consequential loss and otherwise its liability shall be limited to the amounts paid by the Buyer for the Products or the fitting or service concerned. These terms do not affect the Buyer's statutory rights.

R&G RETURNS POLICY (NON-FAULTY GOODS)

Returns must be pre-authorized (if not pre-authorized the return will be rejected). Goods may only be returned direct to us if they were purchased direct from us (customer must prove if necessary). Otherwise to be returned to original vendor. Goods must be in re-sellable condition, in the opinion of R&G. All returns are subject to a 25% restocking and handling fee (25% of the gross value exc. P&P – at the prevailing price at time of purchase). The customer must pay any and all carriage charges. No returns of discontinued products, unless within 14 days of purchase. This policy does not affect your statutory rights and does not refer to faulty goods.



LP0313

MONTAGEANLEITUNG FÜR LP0313BK KENNZEICHENHALTER
YAMAHA MT-07 '21-



ALLE KIT-TEILE SIND AUF DEN NACHFOLGENDEN SEITEN ABGEBILDET UND GEKENNZEICHNET.

DIE ABGEBILDETEN TEILE DIENEN LEDIGLICH ZUR ERKLÄRUNG.

ÜBERPRÜFEN SIE ZUERST, DASS ALLE TEILE VORHANDEN SIND.

LESEN SIE DIE MONTAGEANLEITUNG KOMPLETT DURCH, BEVOR SIE ANFANGEN.

**WENN SIE BEI DER MONTAGE DIESES PRODUKTES UNSICHER SIND, BITTE EINEN
UNSERER HÄNDLER KONTAKTIEREN ODER DAS KIT VON EINEM QUALIFIZIERTEN
ZWEIRAD-MECHANIKER MONTIEREN LASSEN.**

DIE VERPACKUNG DER TEILE STELLT NICHT DIE REIHENFOLGE DER MONTAGE DAR.

HINWEIS FÜR KITS MIT PLASTIKUNTERLEGSCHLEIBEN AN DEN SCHRAUBEN –
DIESE PLASTIK-UNTERLEGSCHLEIBEN WERDEN NICHT FÜR DEN EINBAU BENÖTIGT!

**EINE DIGITALE VERSION DIESER MONTAGEANLEITUNG KANN AUF FOLGENDER
SEITE HERUNTERGELADEN WERDEN:**

WWW.RG-RACING.COM

R&G, Unit 1, Shelley's Lane, East Worldham, Alton, Hampshire, GU34 3AQ
Tel: +44 (0)1420 89007 Fax: +44 (0)1420 87301 www.rg-racing.com Email: info@rg-racing.com



<u>SIE BENÖTIGEN FOLGENDES WERKZEUG</u>	<u>ALLGEM. ANZUGSDREHMOMENT</u>
<ul style="list-style-type: none"> • HEISSLUFTPISTOLE ODER FEUERZEUG • SEITENSCHNEIDER • SATZ INBUSSCHLÜSSEL INKL. 4, 5 & 6MM • KL. FLACHKLINGENSCHRAUBENDREHER • SATZ STECKSCHLÜSSEL INKL. 6 & 8MM • KREUZSCHLITZSCHRAUBENDREHER • KL. MENGE SEKUNDENKLEBER 	<p>M4 SCHRAUBE = 8Nm M5 SCHRAUBE = 12Nm M6 SCHRAUBE = 15Nm M8 SCHRAUBE = 20Nm M10 SCHRAUBE = 40Nm M12 SCHRAUBE = 40Nm</p>

LIEFERUMFANG

ARTIKEL NR.	BESCHREIBUNG	MENGE
ARTIKEL 1	TB0313 TEIL 1 - HAUPT-HALTERUNG	1
ARTIKEL 2	TB0313 TEIL 2 - KENNZEICHENHALTER	1
ARTIKEL 3	TB0159 TEIL3 - ABDECKPLATTE	1
ARTIKEL 4	LA0002 KENNZEICHENBELEUCHTUNG (W/SHROUD)	1
ARTIKEL 5	M6x1.00x16mm INBUSSCHRAUBE	4
ARTIKEL 6	M6x1.00x6mm INBUSSCHRAUBE	3
ARTIKEL 7	I0037 - ADAPTER ORIGINALBLINKER	2
ARTIKEL 8	I0016 - ADAPTER MINIBLINKER	4
ARTIKEL 9	RB0002 GUMMITÜLLE	1
ARTIKEL 10	CON0034 MINIBLINKER VERBINDUNGEN	2
ARTIKEL 11	CON0077 KENNZEICHENBELEUCHTUNG VERBINDUNG	1
ARTIKEL 12	CT100 - KABELBINDER	3
ARTIKEL 13	230MM SCHRUMPFSCHLAUCH	3
ARTIKEL 14	SELBSTKLEBENDER KABELCLIP	2
ARTIKEL 15	IWC0002 ABDECKUNG FÜR BLINKER-KABEL	2
ARTIKEL 16	RÜCKSTRAHLER	1
ARTIKEL 17	6.2MM Ø TANNENBAUM-CLIP	1
ARTIKEL 18	7MM Ø NIETE	2



LP0313

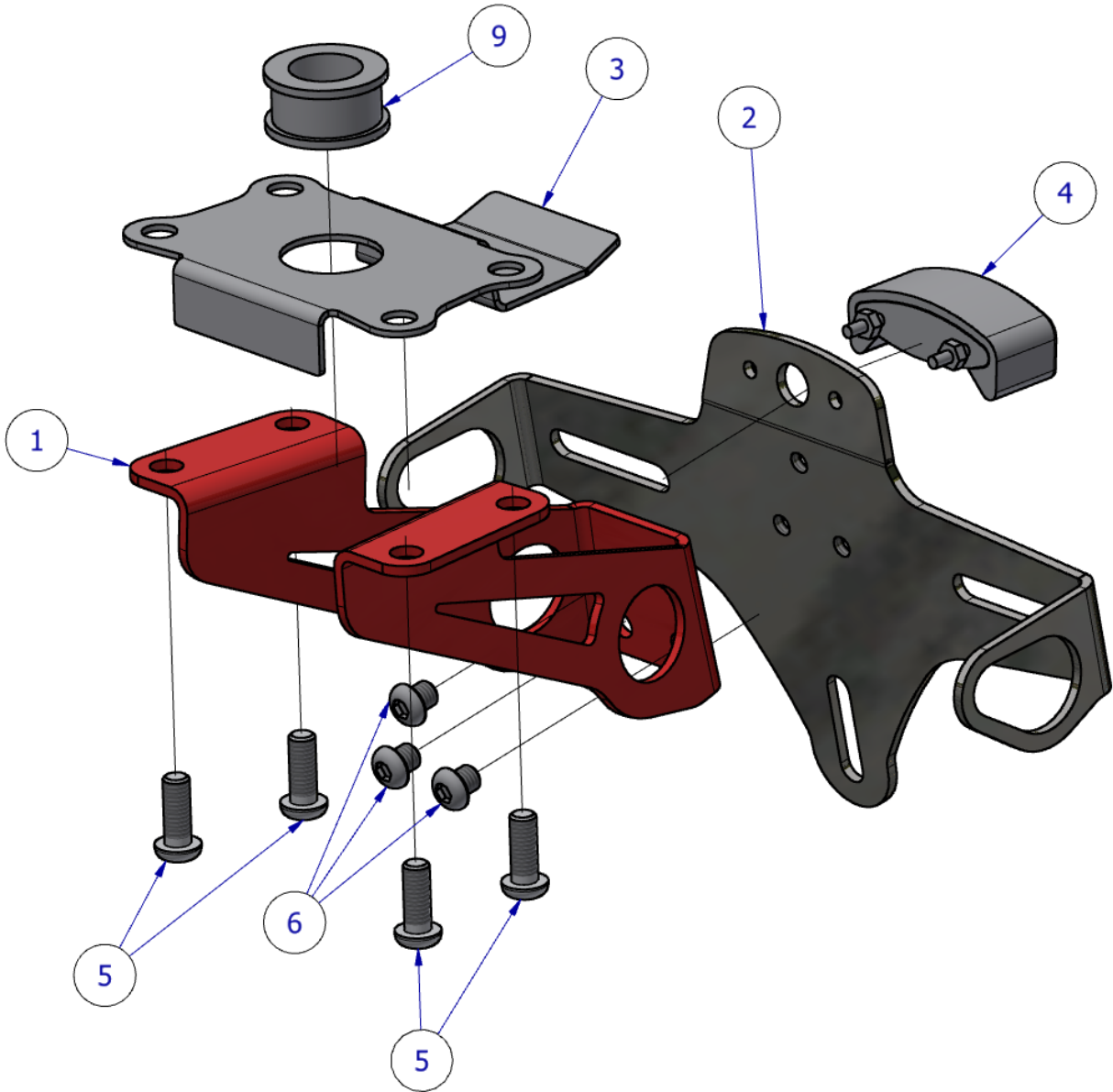





Abbildung 1



Abbildung 2

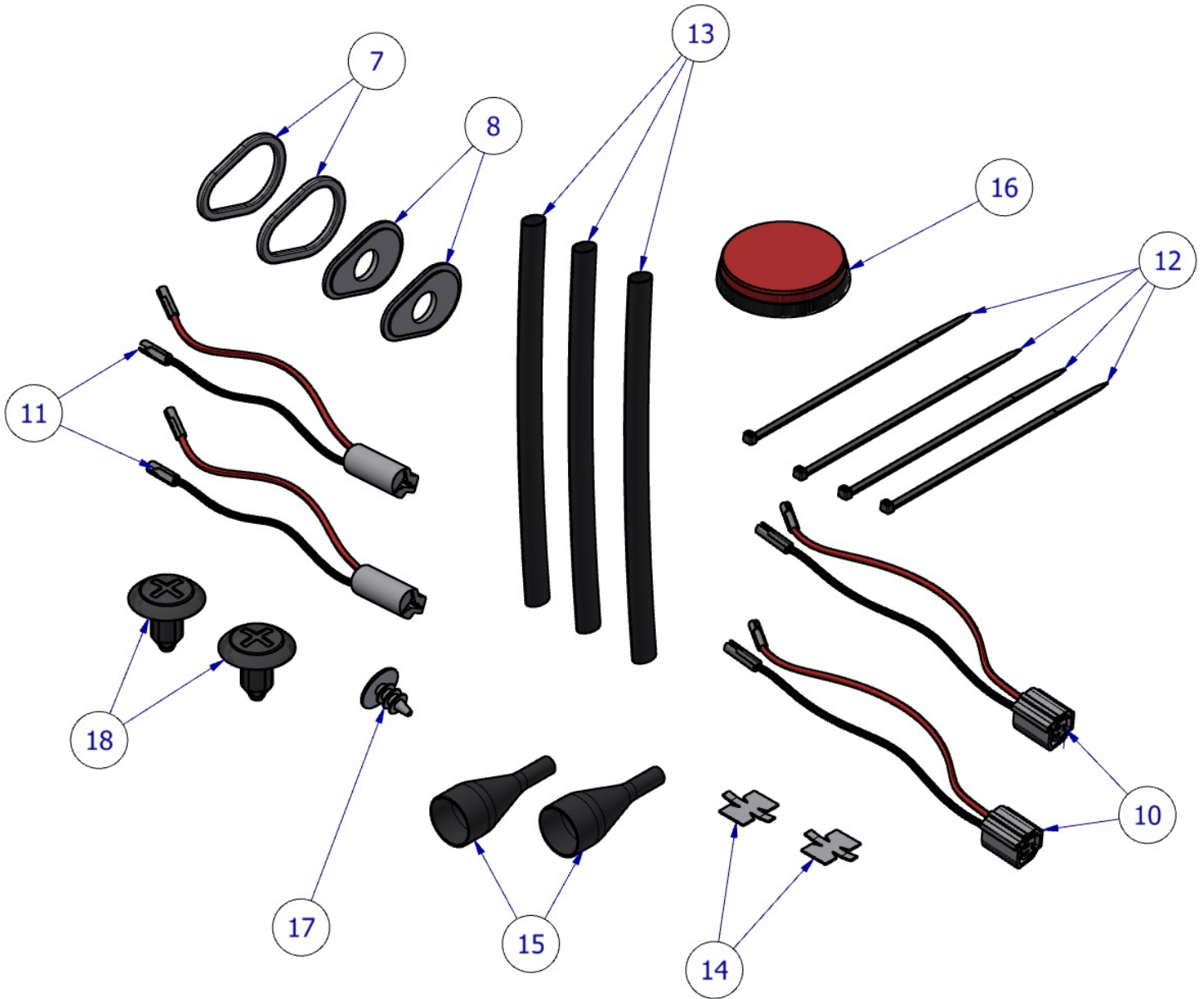

Abbildung 3

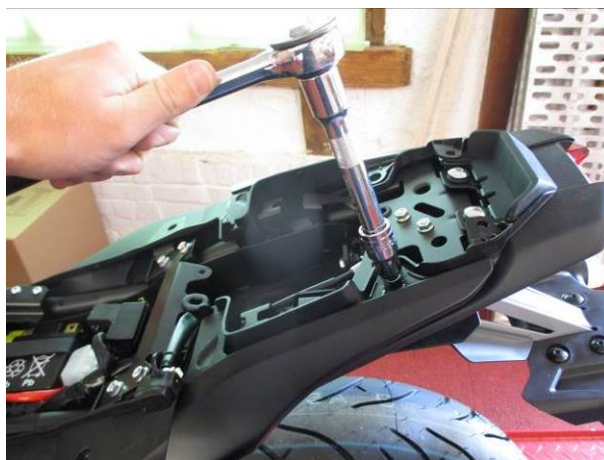

Abbildung 4



Abbildung 5



Abbildung 6



Abbildung 7



Abbildung 8



Abbildung 9



Abbildung 10



Abbildung 11



Abbildung 12

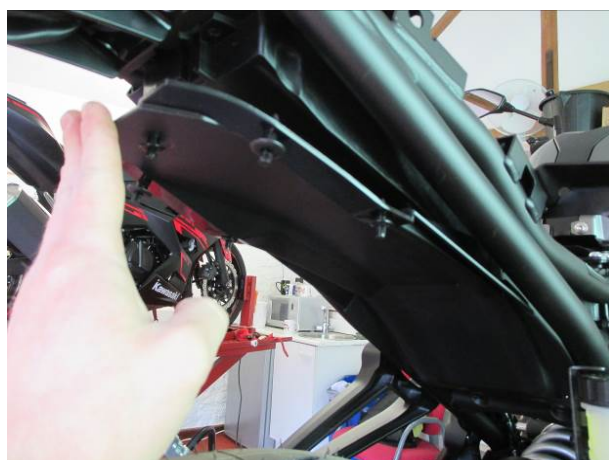

Abbildung 13



Abbildung 14



Abbildung 15



Abbildung 16



Abbildung 17



Abbildung 18



Abbildung 19



Abbildung 20



Abbildung 21



Abbildung 22

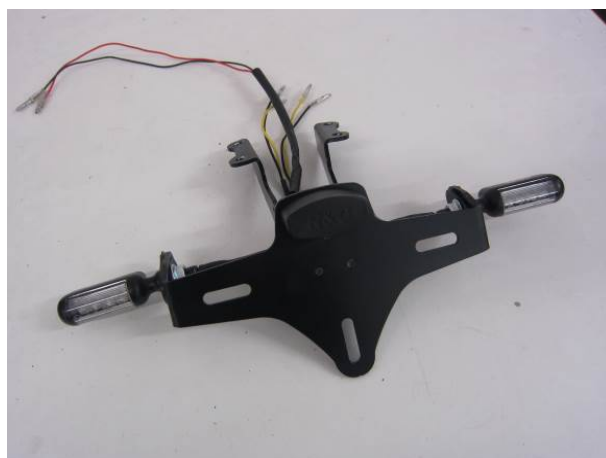

Abbildung 23

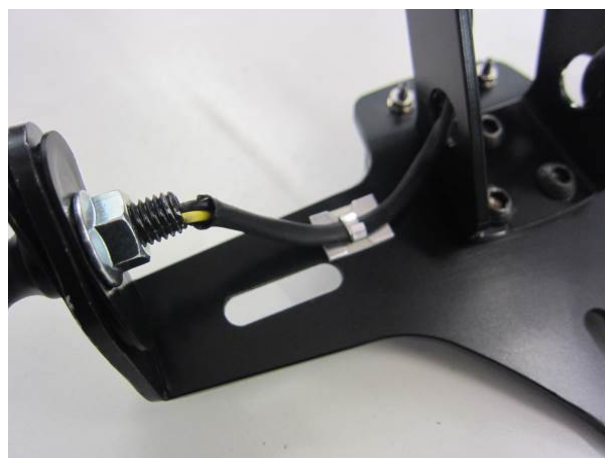

Abbildung 24



Abbildung 25



Abbildung 26

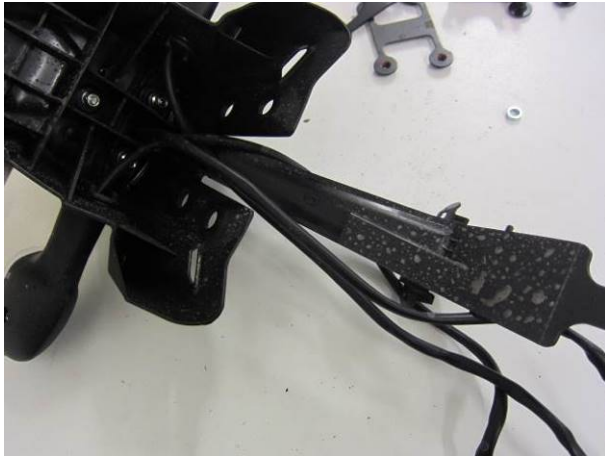

Abbildung 27



Abbildung 28



Abbildung 29



Abbildung 30



Abbildung 31



Abbildung 32



Abbildung 33



Abbildung 34

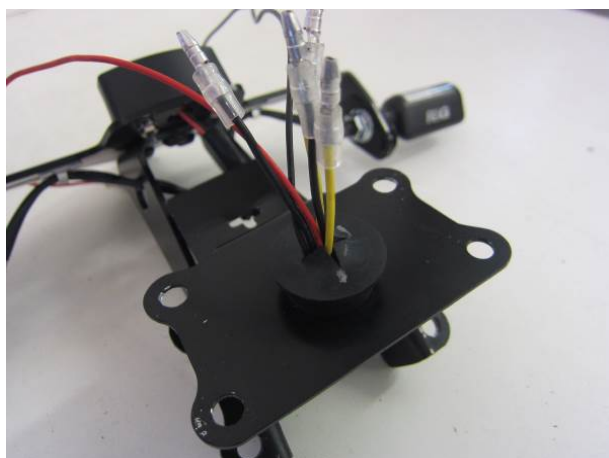

Abbildung 35

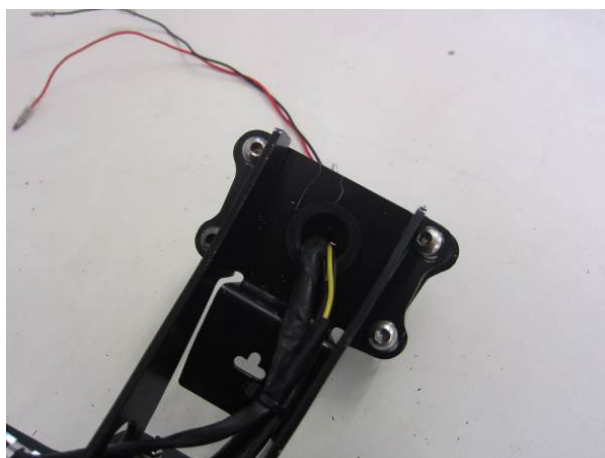

Abbildung 36



Abbildung 37



Abbildung 38



Abbildung 39



Abbildung 40





MONTAGEANLEITUNG

- Um den R&G Kennzeichenhalter zu montieren, entfernen Sie den Beifahrersitz (Schlüssel benutzen), wie in Abbildung 1 abgebildet.
- Entfernen Sie den Fahrersitz, indem Sie die Schrauben entfernen, die den Sitz am Rahmen befestigen.
- Die hintere Verkleidung besteht aus zwei Hauptteilen, die entfernt werden müssen. Entfernen Sie zuerst die zwei Sechskantschrauben hinten am Heck wie in Abbildung 2 abgebildet.
- Entfernen Sie die Verkleidungsschraube, die in Abbildung 3 abgebildet ist an beiden Seiten des Motorrads.
- Entfernen Sie auch die zwei Sechskantschrauben, die hinter dem Gummipuffer versteckt sind – siehe Abbildungen 4 und 5.
- Entfernen Sie die fünf Plastiknieten an der Unterseite des Hecks wie in Abbildung 6 abgebildet.
- Als nächstes die zwei Schrauben oben auf dem Heck entfernen, die das Verbindungsteil aus Gummi in Position befestigen - siehe Abbildung 7.
- An beiden Seiten die Schrauben vorne am seitlichen Verkleidungsteil entfernen - siehe Abbildung 8.
- Jetzt können Sie die hinteren, seitlichen Verkleidungsteile vorsichtig vom Motorrad wegziehen – die Laschen lösen sich von den Gummitüllen im Rahmen – siehe Abbildungen 9 und 10. Das ganze Verkleidungsteil vorsichtig vom Motorrad wegziehen, um zu verhindern, dass die Positionsgeber für die hintere Beleuchtung beschädigt werden.
- Der untere Spritzschutz kann nun vom Motorrad entfernt werden – siehe Abbildung 11.
- Innerhalb des Heckbereiches den Kabelbinder entfernen und die Kabelverbindungen für die Blinker und Kennzeichenbeleuchtung trennen – wie in Abbildung 12 abgebildet. *Es empfiehlt sich, die Verbindungen zu notieren, um den Einbau später zu vereinfachen. Die Blinker entsprechend mit links oder rechts markieren. Dies ist besonders wichtig, wenn Sie R&G Miniblinker verwenden.*
- Entfernen Sie die vier Schrauben, die die Unterseite des original Kennzeichenhalters am Motorrad befestigen und vom Motorrad entfernen – siehe Abbildungen 13 & 14.

Zusammenbau des Kennzeichenhalters

- Den R&G Kennzeichenhalter (Artikel 2 – TB0313 Teil 2) mit den drei M6 x 6mm Inbusschrauben (Artikel 6) an der Haupthalterung (Artikel 1 – TB0313 Teil 1) montieren wie in den Abbildungen 15 & 16 abgebildet.
- Montieren Sie die R&G Kennzeichenbeleuchtung (Artikel 2) wie in Abbildung 17 abgebildet. Benutzen Sie etwas Sekundenkleber, um die Lichtabdeckung in Position zu befestigen. Eine Länge Schrumpfschlauch an den Kabeln anbringen und die Mutter hinten befestigen – siehe Abbildung 18.
- Montieren Sie die R&G Kennzeichenbeleuchtung (Artikel 4) an der Einheit wie in Abbildung 17 abgebildet. Benutzen Sie etwas Sekundenkleber, um die Lichtabdeckung in Position zu befestigen. Eine Länge Schrumpfschlauch an den Kabeln anbringen und die Muttern hinten befestigen – siehe Abbildung 18.
- Wenn Sie die Originalblinker wiederverwenden, überspringen Sie die nächsten Schritte.

Montage der R&G Miniblinker

- Nehmen Sie einen Blinker. Entfernen Sie die Mutter und montieren Sie zwei Miniblinker-Adapter (Artikel 8 – I0016) - die gestuften Flächen sich gegenüberliegend - an den Kabeln. Bitte den Schrumpfschlauch (Artikel 13) verwenden, um die Kabel an den Blinkern zu schützen wie in Abbildung 19 abgebildet.
- Diese nun durch eine der Montageöffnungen fädeln –siehe Abbildung 20.



- Die Mutter am hervorstehenden Gewinde montieren und in Position befestigen. Stellen Sie sicher, dass die gestuften Flächen der Adapter passend in der Öffnung an beiden Seiten der Metallhalterung montiert sind – siehe Abbildung 21.
- Eine IWC0002 Abdeckung (Artikel 15) an den Kabeln montieren, sodass die Mutter für den Blinker vom großen Ende abdeckt ist.
- Diese vier Schritte mit dem zweiten Blinker wiederholen.
- Die Kabel können nun durch die zwei Öffnungen an beiden Seiten des Kennzeichenhalters eingeführt und mit den Kabelbindern und selbstklebenden Clips in Position befestigt werden – siehe Abbildungen 22 & 31.
- Die zwei CON0034 (Artikel 10) mit den Kabeln für die Blinker verbinden mit den Kabelverbindungen wie folgt SCHWARZ zu SCHWARZ und GELB zu SCHWARZ.

Montage der Originalblinker

- Entfernen Sie zuerst die Originalblinker vom original Kennzeichenhalter.
- Nehmen Sie den bereits entfernten Halter und entfernen Sie die vier Schrauben, wie in Abbildung 23 abgebildet.
- Sobald die vier Schrauben entfernt sind, kann die Einheit geteilt werden – siehe Abbildung 24.
- Die Kabel aus dem Plastikkanal herausnehmen – siehe Abbildung 25.
- An der Innenseite der Blinker ist eine kleine Platte aus Kunststoff, die im Kunststoffgehäuse der Blinker-Halterung fixiert ist. Entfernen Sie die Platte und ziehen Sie den Blinker vorsichtig aus der Öffnung wie in den Abbildungen 26 & 27 abgebildet.
- Nehmen Sie die original Adapterplatten für die Originalblinker (Artikel 7 – I0037) und montieren Sie jeweils eine an jedem Blinker-Gummi - siehe Abbildungen 28 & 29.
- Die Blinker in die Montageöffnungen im Kennzeichenhalter einführen (bitte darauf achten, dass die Blinker an der jeweils richtigen Seite des Kennzeichenhalters montiert werden, wie zuvor an den Kabeln markiert) und montieren Sie die kleine Kunststoffplatte im Gummi wieder, um den Blinker sicher zu montieren – siehe Abbildung 30.
- Die Gummitülle an den Originalblinkern muss eventuell geschnitten werden wie in Abbildung 31 abgebildet, um die Verbindung einzufädeln.

Montage des Kennzeichenhalters

- Wenn die Blinker montiert sind, CON0077 (Artikel 11) soll mit den Kabeln für die Kennzeichenbeleuchtung verbunden werden – bitte verbinden wie folgt: *SCHWARZ mit SCHWARZ* und *GRÜN mit ROT*.
- Die Kabel können nun durch die zwei Öffnungen an beiden Seiten der Haupthalterung geführt werden und mit den Kabelbindern und selbstsichernden Clip befestigt (Artikel 14) wie in Abbildung 22 abgebildet.
- Nehmen Sie die Abdeckplatte (Artikel 3 – TB0159 Teil 3) und montieren Sie die Gummitülle (Artikel 9) in der mittleren Öffnung wie in Abbildung 32 abgebildet.
- An den Kennzeichenhalter ansetzen und die Kabel durch die Gummitülle führen.
- Die vier Öffnungen bündig anordnen und die vier M6 x 16mm Inbusschrauben (Artikel 5) zuerst durch den Kennzeichenhalter dann durch die Abdeckplatte eindrehen – siehe Abbildung 33.
- Die Einheit an der Unterseite des Motorrads anbringen – die Kabel durch die große Öffnung im hinteren Hilfsrahmen schieben und die vier M6 x 16mm Inbusschrauben (Artikel 5) in die Hilfsrahmenhalterungen eindrehen – siehe Abbildung 34 & 35. *Während Sie die Schrauben festziehen, bitte darauf achten, dass der kleine Gewindeinsatz an der Unterseite der Rückbeleuchtung in den "T" geformten Ausschnitt an der Metallabdeckung passt – siehe Abbildung 36.*



- Verlegen Sie nun die Kabel wieder, sodass die Montage des Sitzes problemlos ausgeführt werden kann und schließen Sie die Blinker und die Kennzeichenbeleuchtung mit dem richtigen Verbinder am Kabelbaum an. Den zuvor entfernten Kabelclip wieder montieren wie in Abbildung 37 abgebildet.
- Zu diesem Zeitpunkt empfiehlt sich, die Zündung einzuschalten und die ordnungsgemäße Funktion der kompletten Beleuchtung zu überprüfen.
- Benutzen Sie die mitgelieferten Kabelbinder (Artikel 12), um die Kabel ordentlich zu verstauen und montieren Sie alle zuvor entfernten Clips wieder.
- Montieren Sie die untere Abdeckung aus Kunststoff wieder – siehe Abbildung 38.
- Montieren Sie beide Verkleidungsteile am Heck wieder – bitte darauf achten, dass sie auf der unteren Abdeckung liegen wie in Abbildung 39 abgebildet.
- Montieren Sie die Schrauben und Plastiknieten wieder, die die Seitenverkleidungsteile in Position befestigen.
- Montieren Sie die zwei original Plastiknieten wieder in den zwei vorderen Öffnungen und die zwei Plastiknieten vom Kit (Artikel 18) in den zwei hinteren Öffnungen, um die seitlichen Verkleidungsteile an der unteren Abdeckung zu befestigen – siehe Abbildung 40. Montieren Sie die Schnappnagel (Tannenbaum-Clip - Artikel 17) vom Kit, um die Öffnung zu schließen.
- Montieren Sie die zwei übrigen Verbindungsteile für die Verkleidungsteile und die Kreuzschlitzschrauben wieder.
- Stellen Sie sicher, dass alle Schrauben gleichmäßig festgezogen sind.
- Montieren Sie den Sitz wieder, die zwei Schrauben wieder anbringen und den Beifahrersitz wieder montieren.
- Montieren Sie das amtliche Kennzeichen wieder (Bohrungen im Kennzeichen evtl. notwendig).
- **WICHTIG: WENN EIN GROSSES KENNZEICHEN ZU WEIT NACH UNTEN MONTIERT WIRD, BESTEHT BEI SCHWERER LAST ODER DURCH GROSSE BODENWELLEN EIN GERINGES RISIKO, DASS DAS KENNZEICHEN AN DAS HINTERRAD STOSSEN KANN. ES LIEGT IN IHRER VERANTWORTUNG DIES ZU ÜBERPRÜFEN UND, WENN NOTWENDIG, VORZUBEUGENDE MASSNAHMEN ZU ERGREIFEN. DIE NICHTBEACHTUNG DIESER SICHERHEITSHINWEISES KANN ZU SCHWEREN VERLETZUNGEN FÜHREN.**
- Entsprechend der gesetzlichen Vorschriften, den mitgelieferten Rückstrahler (Artikel 17) an die dafür vorgesehene Stelle anbringen.
- Überprüfen Sie die Funktion der kompletten Beleuchtung vor Gebrauch des Fahrzeuges.

AUSGABE 1 28/07/21 (DM)

CONSUMER NOTICE

The catalogue description and any exhibition of samples are only broad indications of the Products and R&G may make design changes which do not diminish their performance or visual appeal and supplying them in such state shall conform to the order. The Buyer acknowledges no representation or warranty (other than as to title) has been given or will apply to the Products other than those in R&G's order or confirmation and the Buyer confirms it has chosen the Products as being of merchantable quality and suitable for its particular purposes. Where R&G fits the Products or undertakes other services it shall exercise reasonable skill and care and rectify any fault free of charge unless the workmanship has been disturbed. The Buyer is responsible for ensuring that the warranty on the motorcycle is not affected by the fitting of the Products. On return of any defective Products R&G shall at its option either supply a replacement or refund the purchase money but shall not be liable if the Products have been modified or used or maintained otherwise than in accordance with R&G's or manufacturer's instructions and good engineering practice or if the defect arises from accident or neglect. Other than identified above and subject to R&G not limiting its liability for causing death and personal injury, it shall not be liable for indirect or consequential loss and otherwise its liability shall be limited to the amounts paid by the Buyer for the Products or the fitting or service concerned. These terms do not affect the Buyer's statutory rights.

**R&G RETURNS POLICY (NON-FAULTY GOODS)**

Returns must be pre-authorized (if not pre-authorized the return will be rejected). Goods may only be returned direct to us if they were purchased direct from us (customer must prove if necessary). Otherwise to be returned to original vendor. Goods must be in re-sellable condition, in the opinion of R&G. All returns are subject to a 25% restocking and handling fee (25% of the gross value exc. P&P – at the prevailing price at time of purchase). The customer must pay any and all carriage charges. No returns of discontinued products, unless within 14 days of purchase. This policy does not affect your statutory rights and does not refer to faulty goods.